

Required Process Data:

- Burner Count
- BTU Release
- Fuel Type
- Applicable Codes, Standards, and Specifications

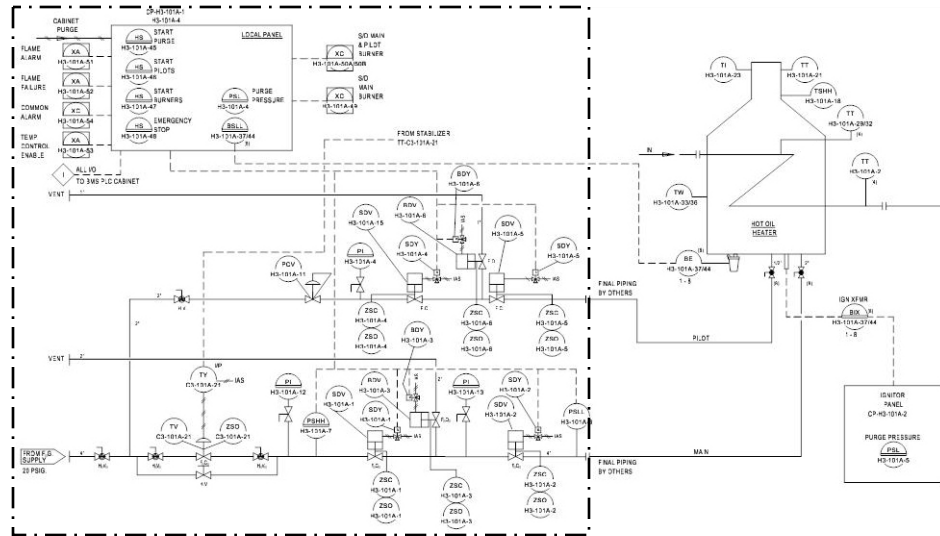

W-M will provide design and final documentation packages including: P&IDs, general arrangement drawings, instrument specifications and electrical drawings.

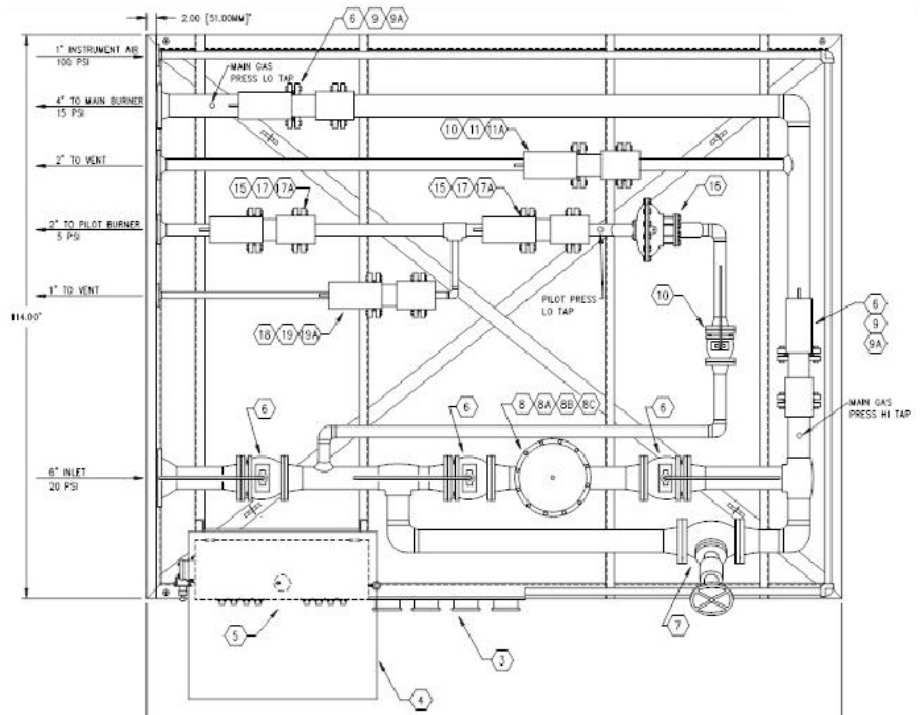

W-M will provide procurement, fabrication, and testing services to assure quality and to minimize on-site construction costs and commissioning schedule.

